

WWW.ISOTUBI.COM  
AUGUST 2023

# ISO TUBI

STAINLESS STEEL  
PIPES AND FITTINGS

**PRODUCT CATALOGUE**  
STAINLESS STEEL TUBES AND FITTINGS



WWW.ISOTUBI.COM

\*Please refer to our website for the latest edition

INTRODUCTION	04
MAIN PRESSFITTING TOOLS	05
FIG 1 COUPLING	06
FIG 2 SLIP COUPLING	06
FIG 3 90° F-F ELBOW	06
FIG 4 90° M-F ELBOW	07
FIG 5 45° F-F ELBOW	07
FIG 6 45° M-F ELBOW	07
FIG 7 FEMALE ANGLE ADAPTOR	08
FIG 8 MALE ANGLE ADAPTOR	08
FIG 9 F ELBOW WITH WALLNUT	08
FIG 10 90° ELBOW WITH PLANE ENDS	09
FIG 11 VALVE CONECT. WITH SWIVEL IN STAINLESS	09
FIG 12 F TEE THREADED ADAPTOR	10
FIG 14 MF REDUCER	10
FIG 15 REDUCING TEE	11
FIG 16 EQUAL TEE	12
FIG 17 FEMALE ADAPTOR	12
FIG 18 MALE ADAPTOR	13
FIG 19 FLANGES ADAPTOR	13
FIG 20 PRE-FORMED PIPE BRIDGE	14
FIG 21 PLUG	14
FIG 22 AIR TUBE PIPE BRIDGE	14
FIG 23 PIPE BRIDGE	15
FIG 24 3 PCS ADAPTOR	15
FIG 25 FF PIPE BRIDGE	15
FIG 26 FEMALE CONNECTOR	16
FIG 27 MALE CONNECTOR	16
FIG 28 PRESS FLANGED ADAPTOR	16
FIG 29 FLEXIBLE TUBES	17
FIG 30 EQUAL OR REDUCED CROSS	17
FIG 31 3 PCS SS BALL VALVE PRESS X PRESS	17
FIG 32 2 PCS SS BALL VALVE FULL PORT	18
FIG 33 45° MALE ANGLE ADAPTOR	18
FIG 34 90° FEMALE ANGLE ADAPTOR	18
FIG 35 90° F ANGLE ADAPTOR WITH SWIVEL NUT	19
FIG 36 MALE TEE THREADED ADAPTOR	19
FIG 37 MALE THREADED CROSS	19
FIG 38 FEMALE THREADED CROSS	20
FIG 39 90° MALE ANGLE ADAPTOR	20
FIG 41 MALE UNION CONNECTOR GAS	20
FIG 42 FEMALE UNION CONNECTOR GAS	21
FIG 45 UNION GAS FEMALE THREADED	21
FIG 46 STRAIGHT UNION WITH PRESSFITTING ON BOTH ENDS	21
FIG 47 HALF COUPLING	22
FIG 48 30° FEMALE-FEMALE F ELBOW	22
FIG 49 30° ELBOW WITH PLAIN ENDS	22
FIG 50 15° FEMALE-FEMALE ELBOW	23
FIG 51 60° FEMALE-FEMALE ELBOW	23
FIG 52 FLANGES ADAPTOR PN6	23
FIG 53 PIPE PENETRATION	24
FIG 54 MALE PLUG	24
FIG 55 WELD ADAPTOR	25
FIG 58 60° ELBOW WITH PLAIN ENDS	25



FIG 59 15° ELBOW WITH PLAIN ENDS	26
FIG 61 TRANSITION FOR GROOVED COUPLING	26
FIG 63 75° ELBOW WITH PLAIN ENDS	26
FIG 64 15° MALE-FEMALE ELBOW	27
FIG 65 M-F PIPE PENETRATION	27
FIG 66 30° MALE-FEMALE ELBOW	27
FIG 71 ELONGATION COMPENSATOR	28
FIG 72 45° ELBOW PLAIN ENDS	28
FIG 76 F DOUBLE ELBOW WITH WALLNUT	28
FIG 77 F 60° MALE-FEMALE ELBOW	29
O-RINGS	29
WELDED TUBES	29
NUMEPRESS GAS	30
FIG 1 COUPLING	31
FIG 2 SLIP COUPLING	31
FIG 3 90° F-F ELBOW	31
FIG 4 90° M-F ELBOW	32
FIG 5 45° F-F ELBOW	32
FIG 6 45° M-F ELBOW	32
FIG 7 FEMALE ANGLE ADAPTOR	33
FIG 8 MALE ANGLE ADAPTOR	33
FIG 9 F ELBOW WITH WALLNUT	33
FIG 11 VALVE CONECT. WITH SWIVEL IN STAINLESS	34
FIG 12 F TEE THREADED ADAPTOR	34
FIG 14 MF REDUCER	34
FIG 15 REDUCING TEE	35
FIG 16 EQUAL TEE	36
FIG 17 FEMALE ADAPTOR	36
FIG 18 MALE ADAPTOR	37
FIG 19 FLANGES ADAPTOR	37
FIG 21 PLUG	38
FIG 28 PRESS FLANGED ADAPTOR	38
FIG 41 MALE UNION CONNECTOR GAS	38
FIG 42 FEMALE UNION CONNECTOR GAS	39
FIG 45 UNION GAS FEMALE THREADED	39
FIG 46 MALE TEE THREADED ADAPTOR	39
O-RINGS	40
GENERAL SALES TERMS	41

Isotubi, S.L., is part of **Grupo Lapuente**, has been working in the stainless steel world for more than 40 years. As a result of this experience our company is able to offer a competitive product which meets the most important quality requirements in the international markets.

Our main challenges are to know about the concrete needs of our customers, to adapt our products and processes to the new technologies and to make a constant effort in improving our customer service.

Both our production and quality control processes are certified by TÜV according to the ISO 9001 norm. We also hold the main European Approvals for our products and processes: AD Merkblatt (Germany), 97/23/CE Pressure Equipments Directive, CERTIF (Portugal), DVGW (Germany), SVGW, ÖVGW, Numepress TÜV product certificate (Spain and Portugal), LLOYDS, WATERMARK, SITAC, CSIRO, NSF, FM, WRAS, STO, ABS and DNV Approval for ships.

### NUMEPRESS SYSTEM

We are presenting in this catalogue our range of **NUMEPRESS** products, the stainless steel tube and Pressfitting system which allows making facilities in a very easy way, without using welding or threads, saving a considerable amount of time and money.

Our factory and warehouse, located in Barcelona, has an important stock at our customer's disposal, so delivery terms are extremely short. As we are manufacturers, we can also offer specialized products to our customers when needed.

These are the main applications of our system: **compressed air, heating facilities, sanitation facilities, fire-extinguishing system (sprinkler), solar energy, plumbing, industrial facilities, shipping facilities, mining and gas.**



# MAIN PRESSFITTINGS TOOLS



The pressfitting tool can be manual, battery or electrically-powered. There is a corresponding easily exchangeable jaw for each diameter which is placed in the tool cylinder.

Most of the machines that exist in the market allow pressing **NUMEPRESS** fittings properly from diameter 15 mm to diameter 54 mm. Each diameter needs its own jaw or collar. There is one machine that presses from 15 mm to 54 mm and another one that presses from 76,1 mm to 168,3 mm.

M profile jaws or collars should always be used. In case of doubt, please ask our technical department.



Technical data	UAP4L	MAP2L19	UAP100L	ACO203XL	ACO 401
Power supply	18 V / 3 Ah	1.5 Ah / 3 Ah	18 V / 3 Ah	18 V / 3,0 Ah Li-Ion	18 V / 3 Ah
Power	-	-	-	450 W	400 W
Dimensions (L x W x H)	512 x 81 x 317 mm	370 x 75 x 116 mm	567 x 81 x 359 mm	460 x 83 x 113 mm	660 x 100 x 250 mm
Weight	4,3 Kg	3,1 Kg	12,7 Kg	3,9 Kg	13 Kg
Piston force	32 kN	19 kN	120 kN	32 kN	100 kN



FIG.1



MAT: AISI 316L

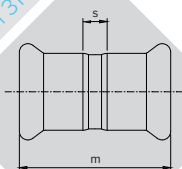

FIG.2



MAT: AISI 316L

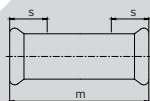
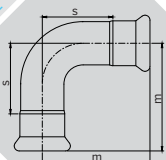

FIG.3



MAT: AISI 316L



### COUPLING

NSF

Dimensions	m	s	N° pieces/Bag	Art. N°	
	15	49	8	20	F01156
	18	50	8	20	F01186
	22	50.5	8	20	F01226
◀ FM ▶	28	55	8	20	F01286
◀ FM ▶	35	70	18	10	F01356
◀ FM ▶	42	78	18	4	F01426
◀ FM ▶	54	85.5	18	4	F01546
◀ FM ▶	76.1	140.5	33	1	F01766
◀ FM ▶	88.9	160	45	1	F01886
◀ FM ▶	108	197	58	1	F011086
	139.7	250	54	1	F0113926
	168.3	300	64	1	F0116826

### SLIP COUPLING

NSF

Dimensions	m	s	N° pieces/Bag	Art. N°	
	15	80	27.5	20	F02156
	18	80	27.5	20	F02186
	22	71	19.5	20	F02226
◀ FM ▶	28	84	22	20	F02286
◀ FM ▶	35	99	26	10	F02356
◀ FM ▶	42	114	30	4	F02426
◀ FM ▶	54	136	34	4	F02546
◀ FM ▶	76.1	226	54	1	F02766
◀ FM ▶	88.9	255	58	1	F02886
◀ FM ▶	108	300	71.5	1	F021086

### 90° F-F ELBOW

NSF

Dimensions	m	s	N° pieces/Bag	Art. N°	
	15	48	28	20	F03156
	18	52	32	20	F03186
	22	61	40	20	F03226
◀ FM ▶	28	71.5	49	10	F03286
◀ FM ▶	35	74	48	10	F03356
◀ FM ▶	42	86	56	4	F03426
◀ FM ▶	54	105.5	71.5	2	F03546
◀ FM ▶	76.1	177	123.5	1	F03766
◀ FM ▶	88.9	181	123	1	F03886
◀ FM ▶	108	214	140	1	F031086
	139.7	314	216	1	F0313926
	168.3	386	268	1	F0316826



NSF

### 90° M-F ELBOW

	Dimensions	m	h	s	N° pieces/Bag	Art. N°
	15	48	67	28	20	F04156
	18	52	65	32	20	F04186
	22	61	74	40	20	F04226
◀ FM ▶	28	71.5	82	49	10	F04286
◀ FM ▶	35	74	85	48	10	F04356
◀ FM ▶	42	86	96.5	56	4	F04426
◀ FM ▶	54	105	113.5	71.5	2	F04546
◀ FM ▶	76.1	177	195	123.5	1	F04766
◀ FM ▶	88.9	181	202	123	1	F04886
◀ FM ▶	108	214	240	140	1	F041086
	139.7	314	322	216	1	F0413926
	168.3	386	404	268	1	F0416826

FIG.4



MAT: AISI 316L

NSF

### 45° F-F ELBOW

	Dimensions	m	s	N° pieces/Bag	Art. N°
	15	34.5	14.5	20	F05156
	18	36	16	20	F05186
	22	41	20	20	F05226
◀ FM ▶	28	46	24	10	F05286
◀ FM ▶	35	49.4	23.4	10	F05356
◀ FM ▶	42	56.7	26.7	4	F05426
◀ FM ▶	54	66.5	33	2	F05546
◀ FM ▶	76.1	111	57.5	1	F05766
◀ FM ▶	88.9	114	56	1	F05886
◀ FM ▶	108	138	64	1	F051086
	139.7	203	105	1	F0513926
	168.3	252	134	1	F0516826

FIG.5



MAT: AISI 316L

NSF

### 45° M-F ELBOW

	Dimensions	m	h	s	N° pieces/Bag	Art. N°
	15	34.5	47	14.5	20	F06156
	18	36	48.5	16	20	F06186
	22	41.0	52	20	20	F06226
◀ FM ▶	28	46	58	24	10	F06286
◀ FM ▶	35	49.4	60.4	23.4	10	F06356
◀ FM ▶	42	56.7	69.7	26.7	4	F06426
◀ FM ▶	54	66.5	75.4	33	2	F06546
◀ FM ▶	76.1	111	128	57.5	1	F06766
◀ FM ▶	88.9	114	135	56	1	F06886
◀ FM ▶	108	138	169	64	1	F061086
	139.7	203	210	105	1	F0613926
	168.3	252	253	134	1	F0616826

FIG.6



MAT: AISI 316L



FIG.7



MAT: AISI 316L

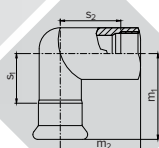

### FEMALE ANGLE ADAPTOR

NSF

Dimensions	m <sub>1</sub>	m <sub>2</sub>	s <sub>1</sub>	s <sub>2</sub>	N° pieces/Bag	Art. N°
15-Rp 1/2"	57	37	37	24	20	F07151/26
18-Rp 1/2"	57	39	37	26	20	F07181/26
18-Rp 3/4"	59	46	39	31	10	F07183/46
22-Rp 3/4"	61,0	46	39	31	10	F07223/46
◀ FM ▶ 28-Rp 1"	67	54	44	37	10	F072816
◀ FM ▶ 35-Rp 1 1/4"	75	63	49	44	10	F073511/46

FIG.8



MAT: AISI 316L

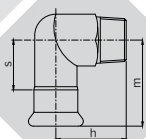

### MALE ANGLE ADAPTOR

NSF

Dimensions	m	h	s	N° pieces/Bag	Art. N°
15-R 1/2"	57	37	37	20	F08151/26
18-R 1/2"	57	39	37	20	F08181/26
18-R 3/4"	59	46	39	10	F08183/46
22-R 3/4"	61,0	46	39	10	F08223/46
◀ FM ▶ 28-R 1"	67	54	44	10	F082816
◀ FM ▶ 35-R 1 1/4"	75	63	49	10	F083511/46
◀ FM ▶ 42-R 1 1/2"	84	67	54	2	F084211/26
◀ FM ▶ 54-R 2"	93	78	60	2	F085426

FIG.9



MAT: AISI 316L

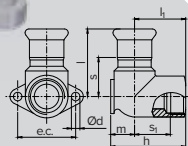

### F ELBOW WITH WALNUT

NSF

Dimensions	m	h	l <sub>1</sub>	l	Ød e.c.	s	s <sub>1</sub>	N° pieces/Bag	Art. N°	
NW-15-Rp 1/2"	14	44	30	50	5	34	28	17	20	F09151/26
NW-18-Rp 1/2"	14	44	30	50	5	34	30	17	20	F09181/26
NW-22-Rp 3/4"	18	52,0	34	55,0	6	40	33	20	20	F09223/46





## 90° ELBOW WITH PLANE ENDS

	Dimensions	$h_1$	$h_{1min.}$	$h_2$	$h_{2min.}$	N° pieces/Bag	Art. N°
	<b>NSF</b> 15	70	58	120	58	20	F10156
	<b>NSF</b> 18	70	63	120	63	20	F10186
	<b>NSF</b> 22	70	70	120	70	10	F10226
◀ <b>FM</b> ▶	<b>NSF</b> 28	80	80	120	80	10	F10286
◀ <b>FM</b> ▶	<b>NSF</b> 35	120	100	200	100	4	F10356
◀ <b>FM</b> ▶	<b>NSF</b> 42	150	120	250	120	2	F10426
◀ <b>FM</b> ▶	<b>NSF</b> 54	200	145	300	145	2	F10546
	<b>NSF</b> 76.1	195	-	195	-	1	F10766
	88.9	202	-	202	-	1	F10886
	108	240	-	240	-	1	F101086

FIG.10



**NSF**

## VALVE CONECT. WITH SWIVEL IN STAINLESS

	Dimensions	m	s	N° pieces/Bag	Art. N°
	15-Rp 1/2"	63.5	37.5	10	F11151/26
	18-Rp 1/2"	62	37	10	F11181/26
	18-Rp 3/4"	61	38	10	F11183/46
	22-Rp 3/4"	64,0	39.5	10	F11223/46
◀ <b>FM</b> ▶	28-Rp 1"	69.5	43.5	10	F112816
◀ <b>FM</b> ▶	35-Rp 1 1/4"	76	42	4	F113511/46
◀ <b>FM</b> ▶	42-Rp 1 1/2"	82.5	46	4	F114211/26
◀ <b>FM</b> ▶	54-Rp 2"	88	50	4	F115426
◀ <b>FM</b> ▶	54-Rp 2 1/2"	105	52.5	1	F115421/26
◀ <b>FM</b> ▶	76.1-Rp 2 1/2"	185.5	113	1	F117621/26
	88.9-Rp 3	186	108.5	1	F118836

FIG.11

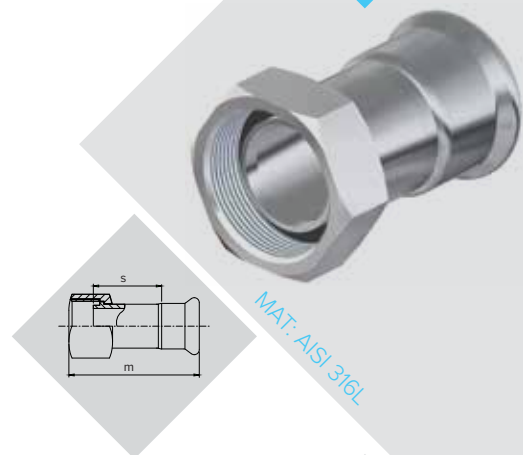
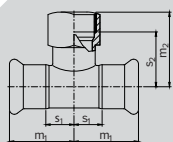

FIG.12



MAT: AISI 316L



### F TEE THREADED ADAPTOR

	Dimensions	m <sub>1</sub>	m <sub>2</sub>	s <sub>1</sub>	s <sub>2</sub>	(*)	Art. N°	
NSF	15-Rp 1/2"-15	32	36	12	23	20	F12151/26	
NSF	18-Rp 1/2"-18	34	37	14	24	20	F12181/26	
NSF	18-Rp 3/4"-18	34	41	14	26	20	F12183/46	
NSF	22-Rp 1/2"-22	37,5	39	16	26	20	F12221/26	
NSF	22-Rp 3/4"-22	37,5	44	16	29	20	F12223/46	
FM	NSF	28-Rp 1/2"-28	41	42	19	29	10	F12281/26
FM	NSF	28-Rp 3/4"-28	41	46	19	31	10	F12283/46
FM	NSF	28-Rp 1"-28	41	47	19	30	10	F122816
FM	NSF	35-Rp 1/2"-35	50	45	24	32	10	F12351/26
FM	NSF	35-Rp 3/4"-35	50	50	24	35	10	F12353/46
FM	NSF	35-Rp 1"-35	50	51	24	34	10	F123516
FM	NSF	35-Rp 1 1/4"-35	50	55	24	36	10	F123511/46
FM	NSF	42-Rp 1/2"-42	57	48	27	35	4	F12421/26
FM	NSF	42-Rp 3/4"-42	57	52	27	37	4	F12423/46
FM	NSF	42-Rp 1"-42	57	53	27	34	4	F124216
FM	NSF	42-Rp 1 1/2"-42	57	61	27	42	4	F124211/26
FM	NSF	54-Rp 1/2"-54	68	55	34	41	2	F12541/26
FM	NSF	54-Rp 3/4"-54	68	58	34	43	2	F12543/46
FM	NSF	54-Rp 1"-54	68	59	34	41	2	F125416
FM	NSF	54-Rp 2"-54	68	76	34	47	2	F125426
FM	NSF	76.1-Rp 3/4"-76.1	113	71	59	56	1	F12763/46
FM	NSF	76.1-Rp 2"-76.1	113	91	59	62	1	F127626
FM	NSF	88.9-Rp 3/4"-88.9	128	78	70	63	1	F12883/46
FM	NSF	88.9-Rp 2"-88.9	128	97	70	68	1	F128826
FM	NSF	108-Rp 3/4"-108	150	87	81	72	1	F121083/46
FM	NSF	108-Rp 2"-108	150	107	81	78	1	F1210826
		139.7-2"-139.7	197	123	99	94	1	F12139226
		139.7-3/4-139.7	197	105,5	99	90,5	1	F121393/426

(\*) N° pieces/Bag

FIG.14

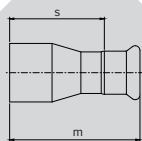

MAT: AISI 316L

### MF REDUCER

D	m	s	(*)	Art. N°		D	m	s	(*)	Art. N°	
18-15	62	42	20	F1418156		76.1-22	122	100.5	1	F1476226	
22-15	64	44	20	F1422156		76.1-28	123	101	1	F1476286	FM
22-18	60	40	20	F1422186		76.1-35	126	100	1	F1476356	FM
28-15	68	48	20	F1428156		76.1-42	130	100	1	F1476426	FM
28-18	66	46	20	F1428186		76.1-54	132	98	1	F1476546	FM
28-22	65	45.5	20	F1428226		88.9-42	159	129	1	F1488426	FM
35-15	77	57	10	F1435156		88.9-54	162	128	1	F1488546	FM
35-18	77	57	10	F1435186		88.9-76.1	185	131	1	F1488766	FM
35-22	82,5	61.5	10	F1435226		108-54	179	145	1	F14108546	FM
35-28	74	52	10	F1435286	FM	108-76.1	198	145	1	F14108766	FM
42-15	85	65	4	F1442156		108-88.9	206	148	1	F14108886	FM
42-18	87	67	4	F1442186		139.7-76.1	347	293	1	F141397626	
42-22	88,0	66.5	4	F1442226	FM	139.7-88.9	340	282	1	F141398826	
42-28	82	60	4	F1442286	FM	139.7-108	307	236	1	F1413910826	
42-35	88	62	4	F1442356		168.3-76.1	278	210	1	F141687626	
54-15	92	72	4	F1454156		168.3-88.9	379	321	1	F141688826	
54-18	93	72,0	4	F1454186		168.3-108	360	289	1	F1416810826	
54-22	93,5	72.5	4	F1454226		168.3-139.7	422	324	1	F1416813926	
54-28	93	71	4	F1454286	FM						
54-35	101	75	4	F1454356	FM						
54-42	101	71	4	F1454426	FM						

(\*) N° pieces/Bag

## REDUCING TEE

	Dimensions	m <sub>1</sub>	m <sub>2</sub>	s <sub>1</sub>	s <sub>2</sub>	(*)	Art. N°
	18-15-18	34	40	14	20	20	F151815186
	22-15-22	37.5	42	16	22	20	F152215226
	22-18-22	37.5	42	16	22	20	F152218226
	28-15-28	41	45	19	25	10	F152815286
	28-18-28	41	45	19	25	10	F152818286
	28-22-28	41	46,5	19	25	10	F152822286
	35-15-35	50	48	24	28	10	F153515356
	35-18-35	50	48	24	28	10	F153518356
	35-22-35	50	49,0	24	28	10	F153522356
◀ FM ▶	35-28-35	50	51	24	28	10	F153528356
	42-15-42	57	51,5	27	31,5	4	F154215426
	42-18-42	57	52	27	31	4	F154218426
	42-22-42	57	52,0	27	31	4	F154222426
◀ FM ▶	42-28-42	57	53	27	31	4	F154228426
◀ FM ▶	42-35-42	57	57	27	31	4	F154235426
	54-15-54	68	56,5	34	37,5	2	F155415546
	54-18-54	68	56,5	34	37,5	2	F155418546
	54-22-54	68	58,0	34	37,5	2	F155422546
◀ FM ▶	54-28-54	68	60	34	38	2	F155428546
◀ FM ▶	54-35-54	68	63	34	37	2	F155435546
◀ FM ▶	54-42-54	68	67	34	37	2	F155442546
	76.1-22-76.1	113	76,5	59	48	1	F157622766
◀ FM ▶	76.1-28-76.1	113	72	59	49	1	F157628766
◀ FM ▶	76.1-35-76.1	113	74	59	48	1	F157635766
◀ FM ▶	76.1-42-76.1	113	76	59	46	1	F157642766
◀ FM ▶	76.1-54-76.1	113	83	59	46,7	1	F157654766
	88.9-22-88.9	128	75	72	55	1	F158822886
◀ FM ▶	88.9-28-88.9	128	79	72	56	1	F158828886
◀ FM ▶	88.9-35-88.9	128	81	72	55	1	F158835886
◀ FM ▶	88.9-42-88.9	128	83	72	53	1	F158842886
◀ FM ▶	88.9-54-88.9	128	90	72	53,7	1	F158854886
◀ FM ▶	88.9-76.1-88.9	128	115	72	63	1	F158876886
	108-22-108	150	86,0	81	64	1	F15108221086
◀ FM ▶	108-28-108	150	88	81	65	1	F15108281086
◀ FM ▶	108-35-108	150	90	81	64	1	F15108351086
◀ FM ▶	108-42-108	150	95	81	65	1	F15108421086
◀ FM ▶	108-54-108	150	99	81	65	1	F15108541086
◀ FM ▶	108-76.1-108	150	126,5	81	73	1	F15108761086
◀ FM ▶	108-88.9-108	150	136	81	74	1	F15108881086
	139.7-76.1-139.7	197	143	99	88	1	F151397613926
	139.7-88.9-139.7	197	153	99	95	1	F151398813926
	139.7-108-139.7	197	167	99	96	1	F1513910813926
	168.3-76.1-168.3	257	157	139	103	1	F151687616826
	168.3-88.9-168.3	257	167	139	110	1	F151688816826
	168.3-108-168.3	257	182	139	111	1	F1516810816826
	168.3-139.7-168.3	257	211	139	113	1	F1516813916826

FIG.15



(\*) N° pieces/Bag

FIG.16



MAT: AISI 316L

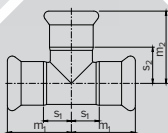

### EQUAL TEE

NSF

Dimensions	m <sub>1</sub>	m <sub>2</sub>	s <sub>1</sub>	s <sub>2</sub>	N° pieces/Bag	Art. N°	
15	32	39	12	19	20	F16156	
18	34	39	14	19	20	F16186	
22	37.5	43,0	16	22,0	20	F16226	
◀ FM ▶	28	41	47	19	25	10	F16286
◀ FM ▶	35	50	53	24	27	10	F16356
◀ FM ▶	42	57	60	27	30	4	F16426
◀ FM ▶	54	68	71	34	37	2	F16546
◀ FM ▶	76.1	113	110	59	55	1	F16766
◀ FM ▶	88.9	128	128	72	69	1	F16886
108	150	154	81	85	1	F161086	
139.7	197	197	99	99	1	F1613926	
168.3	257	235	139	118	1	F1616826	

FIG.17



MAT: AISI 316L

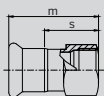

### FEMALE ADAPTOR

NSF

Dimensions	m	s	N° pieces/Bag	Art. N°	
15-Rp 3/8"	54	34	20	F17153/86	
15-Rp 1/2"	54	34	20	F17151/26	
15-Rp 3/4"	58	38	20	F17153/46	
18-Rp 1/2"	54	34	20	F17181/26	
18-Rp 3/4"	58	38	20	F17183/46	
22-Rp 1/2"	54,0	32.5	20	F17221/26	
22-Rp 3/4"	59,0	38	20	F17223/46	
22-Rp 1"	60,0	39.5	20	F172216	
◀ FM ▶	28-Rp 3/4"	60	38	20	F17283/46
◀ FM ▶	28-Rp 1"	60.5	38.5	20	F172816
◀ FM ▶	28-Rp 1 1/4"	65	43	20	F172811/46
◀ FM ▶	35-Rp 1"	64	38	10	F173516
◀ FM ▶	35-Rp 1 1/4"	69	43	10	F173511/46
◀ FM ▶	35-Rp 1 1/2"	73	47	10	F173511/26
◀ FM ▶	42-Rp 1 1/4"	72	42	4	F174211/46
◀ FM ▶	42-Rp 1 1/2"	77	47	4	F174211/26
◀ FM ▶	54-Rp 1 1/2"	81	47	4	F175411/26
◀ FM ▶	54-Rp 2"	90	56	4	F175426
◀ FM ▶	76.1-Rp 2 1/2"	129	75.5	1	F177621/26
◀ FM ▶	88.9-Rp 3"	118	60.5	1	F178836

NSF

## MALE ADAPTOR

	Dimensions	m	s	Nº pieces/Bag	Art. Nº
	15-R 3/8"	48	28	20	F18153/86
	15-R 1/2"	53.5	33.5	20	F18151/26
	15-R 3/4"	57.5	37.5	20	F18153/46
	18-R 1/2"	53.5	33.5	20	F18181/26
	18-R 3/4"	58	38	20	F18183/46
	22-R 1/2"	54,5	33.5	20	F18221/26
	22-R 3/4"	58,5	37.5	20	F18223/46
	22-R 1"	62.0	41	20	F182216
◀ FM ▶	28-R 3/4"	60	38	20	F18283/46
◀ FM ▶	28-R 1"	63	41	20	F182816
◀ FM ▶	28-R 1 1/4"	67	45	20	F182811/46
◀ FM ▶	35-R 1"	67	41	10	F183516
◀ FM ▶	35-R 1 1/4"	71	45	10	F183511/46
◀ FM ▶	35-R 1 1/2"	74	48	10	F183511/26
◀ FM ▶	42-R 1 1/4"	75	45	4	F184211/46
◀ FM ▶	42-R 1 1/2"	78	48	4	F184211/26
◀ FM ▶	54-R 1 1/2"	82	48	4	F185411/26
◀ FM ▶	54-R 2"	84	50	4	F185426
◀ FM ▶	76.1-R 2 1/2"	127.5	74	1	F1821/26
◀ FM ▶	88.9-R 3"	142	86	1	F188836
◀ FM ▶	108-R 4"	155	73	1	F1810846

FIG.18

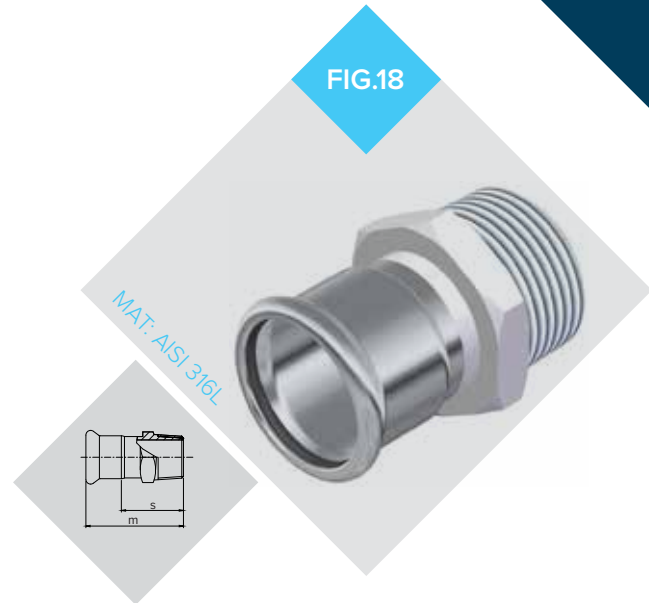

NSF

## FLANGES ADAPTOR

	Dimensions	D	k	b	d <sub>2</sub>	h	n*	z	(*)	Art. Nº
	15-DN 15	95	65	14	14	45	4	25	1	F19156
	18-DN 15	95	65	14	14	47	4	27	1	F19186
	22-DN 20	105	75	16	14	52	4	31	1	F19226
◀ FM ▶	28-DN 25	115	85	16	14	56	4	34	1	F19286
◀ FM ▶	35-DN 32	140	100	18	18	66	4	40	1	F19356
◀ FM ▶	42-DN 40	150	110	18	18	74	4	44	1	F19426
◀ FM ▶	54-DN 50	165	125	18	18	85	4	51	1	F19546
◀ FM ▶	76.1-DN 65	185	145	20	18	132	4	78	1	F19766
◀ FM ▶	88.9-DN 80	200	160	20	18	146	8	91	1	F19886
◀ FM ▶	108-DN 100	220	180	20	18	169	8	100	1	F191086

n\* = Número de tal. de Ø d<sub>2</sub>  
 (\*) Nº pieces/Bag

FIG.19



FIG.20



MAT: AISI 316L

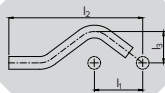

### PRE-FORMED PIPE BRIDGE

NSF

Dimensions	$l_1$	$l_2$	$l_3$	N° pieces/Bag	Art. N°
15	57	158	37	20	F20156
18	60	165	40	20	F20186
22	65	178	44	20	F20226
◀ FM ▶ 28	74	210	50	10	F20286

FIG.21



MAT: AISI 316L

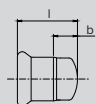

### PLUG

NSF

Dimensions	l	b	N° pieces/Bag	Art. N°
15	36	16	20	F21156
18	36	16	10	F21186
22	41,5	21,5	10	F21226
◀ FM ▶ 28	42	20	10	F21286
◀ FM ▶ 35	51	25	10	F21356
◀ FM ▶ 42	54	24	4	F21426
◀ FM ▶ 54	59	25	4	F21546
◀ FM ▶ 76.1	90	36	1	F21766
◀ FM ▶ 88.9	102	45	1	F21886
◀ FM ▶ 108	125	56	1	F211086

FIG.22



MAT: AISI 316L

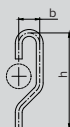

### AIR TUBE PIPE BRIDGE

NSF

Dimensions	b	h	N° pieces/Bag	Art. N°
15	46	208	10	F23156
18	54	218	10	F23186
22	68	246	10	F23226
28	86	283	10	F23286



NSF

## PIPE BRIDGE

Dimensions	N° pieces/Bag	Art. N°
15	20	F23156
18	20	F23186
22	20	F23226
◀ FM ▶ 28	10	F23286

FIG.23

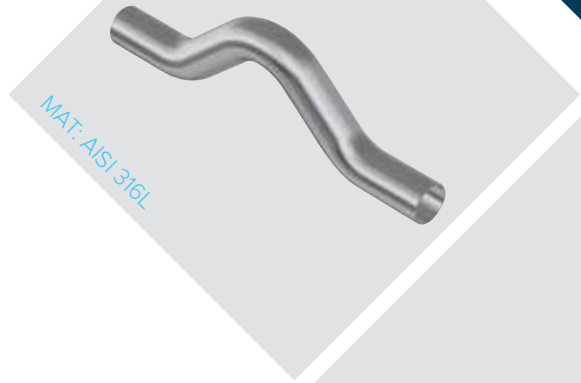

NSF

## 3 PCS ADAPTOR

Dimensions	N° pieces/Bag	Art. N°
15	20	F24156
18	10	F24186
22	10	F24226
28	10	F24286
35	10	F24356
42	4	F24426
54	4	F24546

FIG.24



NSF

## FF PIPE BRIDGE

Dimensions	N° pieces/Bag	Art. N°
15	20	F25156
18	20	F25186
22	20	F25226
◀ FM ▶ 28	10	F25286

FIG.25





FIG.26



MAT: AISI 316L

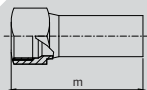

FIG.27



MAT: AISI 316L

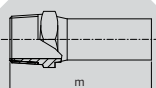
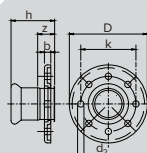

FIG.28



### FEMALE CONNECTOR

NSF

Dimensions	m	N° pieces/Bag	Art. N°
15-1/2"	58	20	F26151/26
18-1/2"	58	20	F26181/26
18-3/4"	62	20	F26183/4
22-1/2"	58	20	F26221/26
22-3/4"	62	20	F26223/46
◀ FM ▶ 28-3/4"	67	20	F26283/46
◀ FM ▶ 28-1"	69	20	F262816
◀ FM ▶ 35-1 1/4"	76	10	F263511/46
◀ FM ▶ 42-1 1/2"	83	4	F264211/26
◀ FM ▶ 54-2"	98.5	4	F265426

### MALE CONNECTOR

NSF

Dimensions	m	N° pieces/Bag	Art. N°
15-1/2"	60	20	F27151/26
18-1/2"	60	20	F27181/26
18-3/4"	64	20	F27183/46
22-1/2"	60	20	F27221/26
22-3/4"	64	20	F27223/46
◀ FM ▶ 28-3/4"	69	20	F27283/46
◀ FM ▶ 28-1"	71	20	F272816
◀ FM ▶ 35-1 1/4"	81	10	F273511/46
◀ FM ▶ 42-1 1/2"	88	4	F274211/26
◀ FM ▶ 54-2"	93	4	F275426

### PRESS FLANGED ADAPTOR

NSF

Dimensions	D	k	b	d <sub>2</sub>	h	n*	z	(*)	Art. N°
◀ FM ▶ 54-DN 50	165	125	19	17.5	78	4	44	1	F28546
◀ FM ▶ 76.1-DN 65	185	145	20	17.5	112	4	70	1	F28766
◀ FM ▶ 88.9-DN 80	200	160	20	17.5	128	8	70	1	F28886
◀ FM ▶ 108-DN 100	220	180	20	17.5	161	8	86	1	F281086
139.7-DN 125	250	210	22	18	138	8	41	1	F2813926
168.3-DN 150	285	240	24	22	171	8	54	1	F2816826

(\*) N° pieces/Bag

FIG.29

## FLEXIBLE TUBES

Available dimensions from 15 to 108 mm according to customers' requirements.

- Minimum length 400 mm
- Maximum length 1500 mm



FIG.30

## NSF EQUAL OR REDUCED CROSS

Available dimensions from 15 to 108 mm according to customers' requirements.



## 3 PCS SS BALL VALVE PRESS X PRESS

Dimensions	s	l	w	h	m	(*)	Art. N°
15	20	111	110	63	71	1	F31156
18	20	111	110	63	71	1	F31186
22	19.5	130	135	68	91	1	F31226
28	22	141	135	70	97	1	F3186
35	26	159	160	85	107	1	F31356
42	30	180	200	90	120	1	F31426
54	34	203	210	100	135	1	F31546
76.1	54	289	320	145	181	1	F31766
88.9	58	340	320	155	224	1	F31886
108	69	424	320	170	286	1	F311086

(\*) N° pieces/Bag

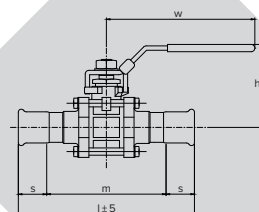
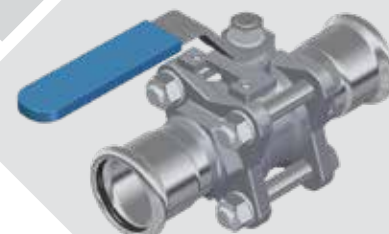
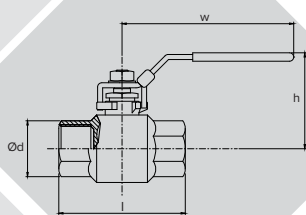

FIG.31



MAT: AISI 316L

FIG.32



### 2 PCS SS BALL VALVE FULL PORT

Dimensions	NPS	d	l	h	w	Art. N°
15	1/2"	15	55	51.5	104	F321/26
20	3/4"	20	70	62	122	F323/46
25	1"	25	83	65	122	F3216
32	1-1/4"	32	91	82	180	F3211/46
40	1-1/2"	38	103	88	205	F3211/26
50	2"	50	120	106	219	F3226

FIG.33

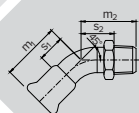

### 45° MALE ANGLE ADAPTOR

NSF

Dimensions	m <sub>1</sub>	s <sub>1</sub>	m <sub>2</sub>	s <sub>2</sub>	N° pieces/Bag	Art. N°
15-R 1/2"	34.5	14	40	25	20	F33151/26
18-R 1/2"	36	16	41.5	26.5	20	F33181/26
18-R 3/4"	36	16	45.5	28.5	20	F33183/46
22-R 3/4"	41	20	48.5	31.5	20	F33223/46
◀ FM ▶ 28-R 1"	46	24	56	36	10	F332816

FIG.34

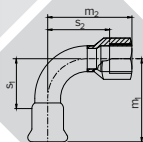

### 90° FEMALE ANGLE ADAPTOR

NSF

Dimensions	m <sub>1</sub>	s <sub>1</sub>	m <sub>2</sub>	s <sub>2</sub>	N° pieces/Bag	Art. N°
15-Rp 3/8"	48	28	52	39	20	F34151/26
15-Rp 1/2"	48	28	52	39	20	F34153/86
18-Rp 1/2"	52	32	58	45	20	F34181/26
18-Rp 3/4"	52	32	62	47	20	F34183/46
22-Rp 3/4"	61	40	67	52	20	F34223/46
◀ FM ▶ 28-Rp 1"	71.5	49	78	61	10	F342816
◀ FM ▶ 35-Rp 1 1/4"	86	60	94	75	10	F343511/46



**NSF** 90° F ANGLE ADAPTOR WITH SWIVEL NUT

	Dimensions	m <sub>1</sub>	s <sub>1</sub>	m <sub>2</sub>	s <sub>2</sub>	N° pieces/Bag	Art. N°
	15-Rp 1/2"	48	28	48	39	20	F35151/26
	18-Rp 1/2"	52	32	62	53	20	F35181/26
	18-Rp 3/4"	52	32	60	51	20	F35183/46
◀ FM ▶	22-Rp 3/4"	61	40	70	61	20	F35223/46
◀ FM ▶	28-Rp 1"	71.5	49	83	73	10	F352816
◀ FM ▶	35-Rp 1 1/4"	86	60	101	89	10	F353511/46
◀ FM ▶	42-Rp 1 1/2"	112	82	126.5	115	4	F354211/26
	54-Rp 2"	105	71.5	119	106.5	4	F355426

FIG.35

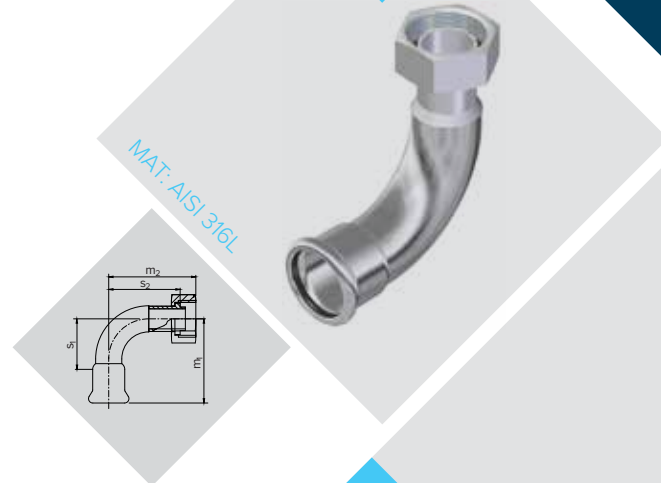

**NSF** MALE TEE THREADED ADAPTOR

	Dimensions	m <sub>1</sub>	m <sub>2</sub>	s <sub>1</sub>	s <sub>2</sub>	N° pieces/Bag	Art. N°
	15-R 3/8"	32	34.5	12	21.5	20	F36153/86
	15-R 1/2"	32	36	12	21	20	F36151/26
	18-R 1/2"	34	36.5	14	21.5	20	F36181/26
	18-R 3/4"	34	40.5	14	23.5	20	F36183/46
	22-R 3/4"	35.5	43.5	16	26.5	20	F36223/46
◀ FM ▶	28-R 1"	41	49.5	19	29.5	10	F362816
◀ FM ▶	35-R 1 1/4"	50	56.5	24	34.5	10	F363511/46

FIG.36

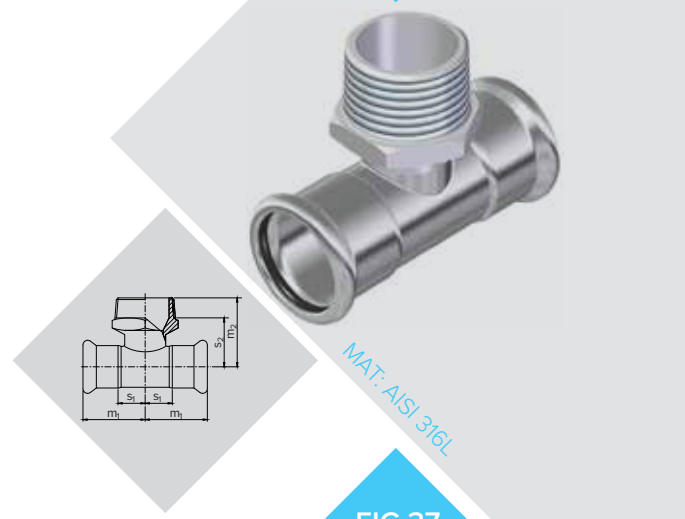

FIG.37

**NSF** MALE THREADED CROSS

Available dimensions from 15 to 108 mm according to customers' requirements.



FIG.38



MAT: AISI 316L

### FEMALE THREADED CROSS

NSF

Available dimensions from 15 to 108 mm according to customers' requirements.

FIG.39

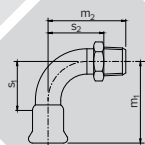

### 90° MALE ANGLE ADAPTOR

NSF

Dimensions	m <sub>1</sub>	s <sub>1</sub>	m <sub>2</sub>	s <sub>2</sub>	N° pieces/Bag	Art. N°
15-R 3/8"	48	28	49	36	20	F39153/86
15-R 1/2"	48	28	53	38	20	F39151/26
18-R 1/2"	52	32	57	42	20	F39181/26
18-R 3/4"	52	32	61	44	20	F39183/46
22-R 3/4"	61	40	68	51	20	F39223/46
◀ FM ▶ 28-R 1"	71.5	49	81	61	10	F392816
◀ FM ▶ 35-R 1 1/4"	86	60	96	74	10	F393511/46
◀ FM ▶ 42-R 1 1/2"	112	82	121	96	4	F394211/26
◀ FM ▶ 54-R 2"	105.2	71.5	112	85	2	F395426

FIG.41

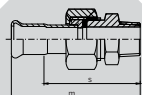

### MALE UNION CONNECTOR GAS

NSF

Dimensions	m	s	N° pieces/Bag	Art. N°
15-1/2"	72	52	20	F41151/26
15-3/4"	74.5	54.5	20	F41153/46
18-1/2"	74	54	20	F41181/26
18-3/4"	76.5	56.5	20	F41183/46
22-1"	83.5	64	20	F412216
22-3/4"	79	58	20	F41223/46
◀ FM ▶ 28-1"	90.5	68.5	20	F412816
◀ FM ▶ 28-1 1/4"	94	72	20	F412811/46
◀ FM ▶ 35-1 1/4"	104.5	78.5	10	F413511/46
◀ FM ▶ 42-1 1/2"	113	83	4	F414211/26
◀ FM ▶ 54-2"	134	100	2	F415426



NSF

## FEMALE UNION CONNECTOR GAS

	Dimensions	m	s	N° pieces/Bag	Art. N°
	15-1/2"	67	47	20	F42151/26
	15-3/4"	69	49	20	F42153/46
	18-1/2"	69	47	20	F42181/26
	18-3/4"	71	51	20	F42183/46
	22-1"	77	57.5	20	F422216
	22-3/4"	73.5	54	20	F42223/46
◀ FM ▶	28-1"	84.5	62.5	20	F422816
◀ FM ▶	28-1 1/4"	84.5	62.5	20	F422811/46
◀ FM ▶	35-1 1/4"	96	70	10	F423511/46
◀ FM ▶	42-1 1/2"	104.5	74.5	4	F424211/26
◀ FM ▶	54-2"	126.5	92.5	2	F425426

FIG.42



NSF

## UNION GAS FEMALE THREADED

	Dimensions	m	s	N° pieces/Bag	Art. N°
	15-1/2"	63.5	34.5	20	F45151/26
	15-3/4"	46	19.5	20	F45153/46
	18-1/2"	65.5	34.5	20	F45181/26
	18-3/4"	48	21.5	20	F45183/46
	22-3/4"	65	36.5	20	F45223/46
	22-1"	50.5	23.5	20	F452216
	28-1"	73	39.5	20	F452816
◀ FM ▶	28-1 1/4"	58	27.5	20	F452811/46
	35-1 1/4"	76	38	10	F453511/46
◀ FM ▶	35-1 1/2"	66.5	32	10	F453511/26
	42-1 1/2"	82.5	41	4	F454211/26
◀ FM ▶	42-2"	75	35.5	4	F454226
◀ FM ▶	54-2"	91	47	2	F455426

FIG.45



NSF

## STRAIGHT UNION WITH PRESSFITTING ON BOTH ENDS

	Dimensions	m	s	N° pieces/Bag	Art. N°
	15	95	20	20	F46156
	18	99	20	20	F46186
	22	104	19.4	20	F46226
◀ FM ▶	28	117	22.2	20	F46286
◀ FM ▶	35	135.5	26	10	F46356
◀ FM ▶	42	152	30	4	F46426
◀ FM ▶	54	157	35	2	F46546

FIG.46

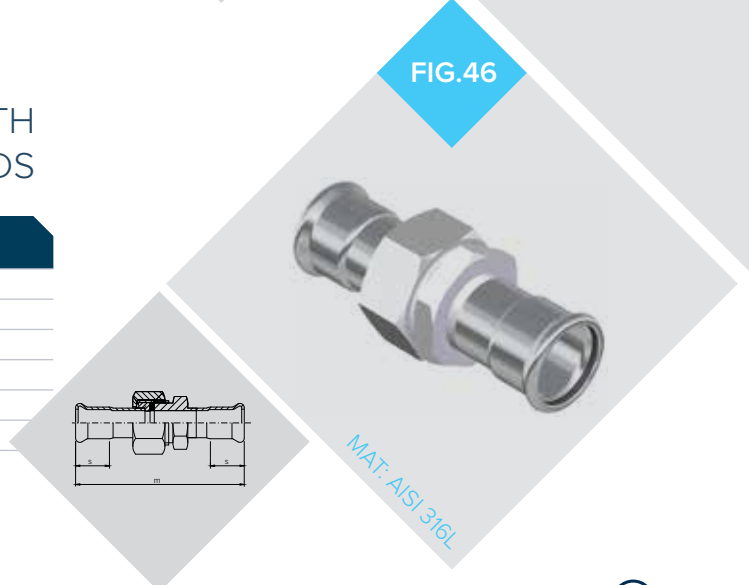
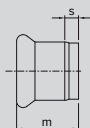

FIG.47



MAT: AISI 316L



### HALF COUPLING

Dimensions	m	s	N° pieces/Bag	Art. N°
15	28	8	20	F47156
18	28	8	20	F47186
22	27.5	8	20	F47226
28	30.5	8	20	F47286
35	34	8	10	F47356
42	38	8	4	F47426
54	42	8	4	F47546
76.1	69.5	16	1	F4776,16
88.9	79.5	21.5	1	F4788,96
108	96.5	27.5	1	F471086

FIG.48



MAT: AISI 316L

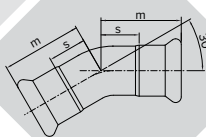

### 30° FEMALE-FEMALE ELBOW

Dimensions	m	s	N° pieces/Bag	Art. N°
15	31	11	20	F48156
18	32	12	20	F48186
22	34.5	15	20	F48226
28	40	17.5	10	F48286
35	46.5	20.5	10	F48356
42	56.5	26.5	4	F48426
54	58	24	2	F48546
76.1	93.5	40.5	1	F48766
88.9	97	39.5	1	F4886
108	108	39	1	F481086

FIG.49



MAT: AISI 316L

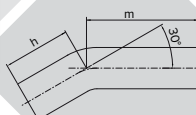

### CODO DE AJUSTE 30° 30° ELBOW WITH PLAIN ENDS

Dimensions	m	h	N° pieces/Bag	Art. N°
15	103	53	20	F49156
18	100	50	20	F49186
22	95	45	20	F49226
28	88.5	48.5	10	F49286
35	160.5	80.5	10	F49356
42	194.5	94.5	4	F49426
54	229	129	2	F49546
76.1	111.5	111.5	1	F49766
88.9	118.5	118.5	1	F49886
108	145	145	1	F491086





## 15° FEMALE-FEMALE ELBOW

Dimensions	m	s	N° pieces/Bag	Art. N°
15	28.5	9	20	F50156
18	28.5	9.5	20	F50186
22	30.7	10.5	20	F50226
28	34	12	10	F50286
35	39	13	10	F50356
42	46	16	4	F50426
54	53	19	2	F50546
76.1	78	24.5	1	F50766
88.9	81.5	24	1	F50886
108	93.5	24	1	F501086

FIG.50



## 60° FEMALE-FEMALE ELBOW

Dimensions	m	s	N° pieces/Bag	Art. N°
15	38	18	20	F51156
18	40.5	20.5	20	F51186
22	46.5	25.5	20	F51226
28	53	31	10	F51286
35	63	37	10	F51356
42	80	50	4	F51426
54	78	44	2	F51546
76.1	129	75	1	F51766
88.9	132.5	76	1	F51886
108	141.5	72.5	1	F511086

FIG.51



## FLANGES ADAPTOR PN6

Dimensions	D	k	b	d <sub>2</sub>	h	n*	z	(*)	Art. N°
15-DN 15	80	55	12	11	61	4	41	1	F52156
18-DN 15	80	55	12	11	46	4	26	1	F52186
22-DN 20	90	65	14	11	52.5	4	33	1	F52226
28-DN 25	100	75	14	11	52	4	30	1	F52286
35-DN 32	120	90	16	14	65	4	39	1	F52356
42-DN 40	130	100	16	14	77	4	47	1	F52426
54-DN 50	140	110	16	14	68	4	34	1	F52546
76.1-DN 65	160	130	16	14	114	4	60	1	F52766
88.9-DN 80	190	150	18	18	128	4	70	1	F52886
108-DN 100	210	170	18	18	158	4	89	1	F521086

FIG.52



n\* = Número de tal. de Ø d<sub>2</sub>  
 (\*) N° pieces/Bag

FIG.53



MAT: AISI 316L

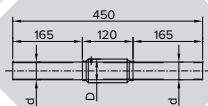

### PIPE PENETRATION

Dimensions	d	D	N° pieces/Bag	Art. N°
15	15	25	1	F53156
18	18	30	1	F53186
22	22	33	1	F53226
28	28	37	1	F53286
35	35	43.5	1	F53356
42	42	53	1	F53426
54	54	69	1	F53546
76.1	76.1	88.5	1	F53766
88.9	88.9	107	1	F53886
108	108	131.5	1	F531086

FIG.54



MAT: AISI 316L

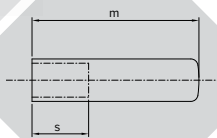

### MALE PLUG

Dimensions	s	m	N° pieces/Bag	Art. N°
15	20	59	20	F54156
18	21	63	20	F54186
22	21	66	20	F54226
28	24	75	10	F54286
35	27	83	10	F54356
42	32	104	4	F54426
54	39	118	4	F54546
76.1	55	172	1	F54766
88.9	64	192	1	F54886
108	78	226	1	F541086



## WELD ADAPTOR

Dimensions	m	s	N° pieces/Bag	Art. N°
DN 15	130	110	20	F55156
DN 18	130	110	20	F55186
DN 22	129.5	110	20	F55226
DN 28	132.5	110	20	F55286
DN 35	136	110	10	F55356
DN 42	140	110	4	F55426
DN 54	144	110	2	F55546

FIG.55

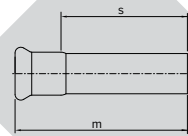

MAT: AISI 316L

## 60° ELBOW WITH PLAIN ENDS

Dimensions	m	h	N° pieces/Bag	Art. N°
15	110	60	20	F58156
18	108	58	20	F58186
22	106	56	20	F58226
28	102	62	10	F58286
35	177	97	10	F58356
42	218	118	4	F58426
54	259	159	2	F58546
76.1	147	147	1	F58766
88.9	154	154	1	F58886
108	185	185	1	F581086

FIG.58

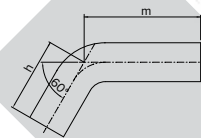

MAT: AISI 316L

FIG.59



MAT: AISI 316L

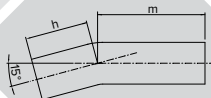

### 15° ELBOW WITH PLAIN ENDS

Dimensions	m	h	N° pieces/Bag	Art. N°
15	97	47	20	F59156
18	96.5	46.5	20	F59186
22	90.5	40.5	20	F59226
28	83	43	10	F59286
35	153	73	10	F59356
42	184	84	4	F59426
54	216	116	2	F59546
76.1	96	96	1	F59766
88.9	103	103	1	F59886
108	127	127	1	F591086

FIG.61



MAT: AISI 316L

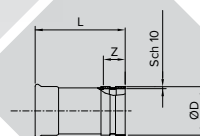

### TRANSITION FOR GROOVED COUPLING

Dimensions	D	L	Z	N° pieces/Bag	Art. N°
DN 28 x 33.7	33.7	80	40	20	F61286
DN 35 x 42.4	42.4	88.5	40	10	F61356
DN 42 x 48.3	48.3	96	40	4	F61426
DN 54 x 60.3	60.3	107	40	4	F61546
DN 76.1 x 73	73	152	40	1	F6176736
DN 76.1 x 76.1	76.1	152	40	1	F6176766
DN 88.9 x 88.9	88.9	166	40	1	F61886

FIG.63



MAT: AISI 316L

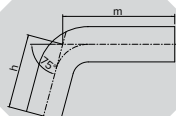

### 75° ELBOW WITH PLAIN ENDS

Dimensions	m	h	N° pieces/Bag	Art. N°
15	115	65	20	F63156
18	114	64	20	F63186
22	112	62	20	F63226
28	110	70	10	F63286
35	187	107	10	F63356
42	233	133	4	F63426
54	278	178	2	F63546
76.1	168.5	168.5	1	F63766
88.9	175.5	175.5	1	F63886
108	209.5	209.5	1	F631086

## 15° MALE-FEMALE ELBOW

Dimensions	m	h	s	N° pieces/Bag	Art. N°
15	28	41	8	20	F64156
18	28.5	43.5	8.5	20	F64186
22	30	44.5	10.5	20	F64226
28	34	48	11.5	10	F64286
35	39	50	13	10	F64356
42	46	56.5	16	4	F64426
54	53	65	19.5	2	F64546
76.1	78	96	24.5	1	F64766
88.9	81.5	103	24	1	F64886
108	96	127	27.5	1	F641086

FIG.64



## M-F PIPE PENETRATION

Dimensions	d	D	L	N° pieces/Bag	Art. N°
15	15	25	672	1	F65156
18	18	30	672	1	F65186
22	22	33	672	1	F65226
28	28	37	670	1	F65286
35	35	43.5	666	1	F65356
42	42	53	662	1	F65426
54	54	69	658	1	F65546
76.1	76.1	88.5	630	1	F65766
88.9	88.9	107	620	1	F65886
108	108	131.5	603	1	F651086

FIG.65



## 30° MALE-FEMALE ELBOW

Dimensions	m	h	s	N° pieces/Bag	Art. N°
15	31	44	11	20	F66156
18	32	47	12	20	F66186
22	34.5	49	15	20	F66226
28	40	53.5	17.5	10	F66286
35	46.5	57.5	20.5	10	F66356
42	56.5	67	26.5	4	F66426
54	66.2	78	32.5	2	F66546
76.1	93.5	111.5	40	1	F66766
88.9	97	118.5	39.5	1	F66886
108	114	145	45	1	F661086

FIG.66



FIG.71



MAT: AISI 316L

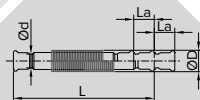

### ELONGATION COMPENSATOR

Dimensions	øD	La	L	N° pieces/Bag	Art. N°
15	26	15	235	1	F71156
18	26	15	235	1	F71186
22	31	15	241	1	F71226
28	40	15	241	1	F71286
35	40	15	251	1	F71356
42	48	15	261	1	F71426
54	71	15	269	1	F714546
76.1	88	20	353	1	F71766
88.9	105	25	494	1	F71886
108	128	25	434	1	F711086

FIG.72



MAT: AISI 316L

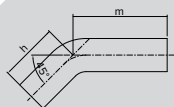

### 45° ELBOW WITH PLAIN ENDS

Dimensions	m	h	N° pieces/Bag	Art. N°
15	106.5	56.5	20	F72156
18	104	54	20	F72186
22	100	50	20	F72226
28	95	55	10	F72286
35	168.5	88.5	10	F72356
42	205.5	105.5	4	F72426
54	243	143	2	F72546
76.1	128	128	1	F72766
88.9	135	135	1	F72886
108	164	164	1	F721086

FIG.76



MAT: AISI 316L

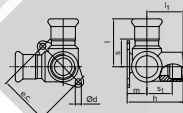

### F DOUBLE ELBOW WITH WALLNUT

Dimensions	h	m	l	l <sub>1</sub>	ød	e.c.	s	s <sub>1</sub>	Art. N°
NW-15-Rp 1/2"	44	14	50	30	5	39	28	17	F76151/26



## 60° MALE-FEMALE ELBOW

Dimensions	m	h	s	N° pieces/Bag	Art. N°
15	52	61	32	20	F77156
18	57	65	37	20	F77186
22	65	75	44	20	F77226
28	77	84	53	10	F77286
35	75	78	48	10	F77356
42	87	91	55	4	F77426
54	97	102	59	2	F77546
76.1	141	148	86	1	F77766
88.9	146	154	82	1	F77886
108	182	191	104	1	F771086



## O-RINGS

Dimensions	N° pieces/Bag
15	10
18	10
22	10
28	10
35	10
42	10
54	10
76,1	4
88,9	4
108	4
139,7	1
168,3	1

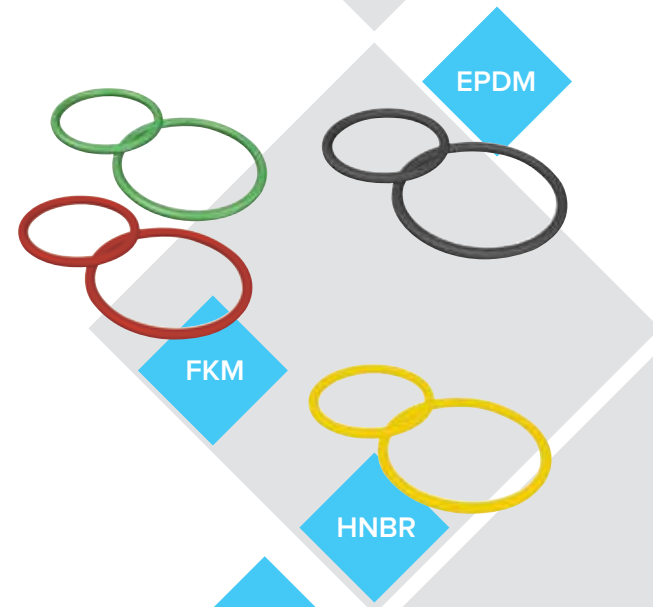

NOTE: Our fittings from 15 to 54mm are fitted with an EPDM LBP-function o-ring.

## WELDED TUBES

Dimensions	O.D. x wall thickness	O.D. x wall thickness
DN 12	15 x 1	15 x 0,6
DN 15	18 x 1	18 x 0,7
DN 20	22 x 1,2	22 x 0,7
DN 25	28 x 1,2	28 x 0,8
DN 32	35 x 1,5	35 x 1
DN 40	42 x 1,5	42 x 1,2
DN 50	54 x 1,5	54 x 1,2
DN 65	76,1 x 2	76,1 x 1,5
DN 80	88,9 x 2	88,9 x 2
DN 100	108 x 2	108 x 2
DN 125	139,7 x 2,6	139,7 x 2
DN 150	168,3 x 2,6	168,3 x 2





NUMEPRESS GAS



NUMEPRESS  
GAS  
CERTIFIED  
PRODUCTS  
gas installations



Kitemark by BSI  
Nr. KM 672-498



## COUPLING

Dimensions	m	s	N° pieces/Bag	Art. N°
15	49	8	20	GASF01156
18	50	8	20	GASF01186
22	50.5	8	20	GASF01226
28	55	8	20	GASF01286
35	70	18	10	GASF01356
42	78	18	4	GASF01426
54	85.5	18	4	GASF01546
76.1	140.5	33	1	GASF01766
88.9	160	45	1	GASF01886
108	197	58	1	GASF011086
139.7	250	54	1	GASF0113926
168.3	300	64	1	GASF0116826



## SLIP COUPLING

Dimensions	m	s	N° pieces/Bag	Art. N°
15	80	27.5	20	GASF02156
18	80	27.5	20	GASF02186
22	71	19.5	20	GASF02226
28	84	22	20	GASF02286
35	99	26	10	GASF02356
42	114	30	4	GASF02426
54	136	34	4	GASF02546
76.1	226	54	1	GASF02766
88.9	255	58	1	GASF02886
108	300	71.5	1	GASF021086

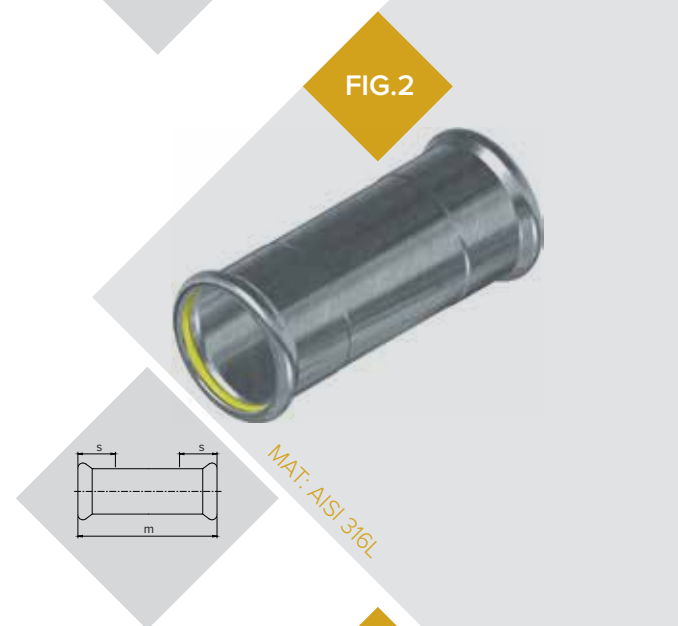

## 90° F-F ELBOW

Dimensions	m	s	N° pieces/Bag	Art. N°
15	48	28	20	GASF03156
18	52	32	20	GASF03186
22	61	40	20	GASF03226
28	71,5	49	10	GASF03286
35	74	48	10	GASF03356
42	86	56	4	GASF03426
54	105,5	71,5	2	GASF03546
76,1	177	123,5	1	GASF03766
88,9	181	123	1	GASF03886
108	209	140	1	GASF031086
139,7	314	216	1	GASF0313926
168,3	386	268	1	GASF0316826



FIG.4



MAT: AISI 316L

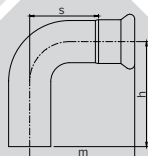

FIG.5



MAT: AISI 316L

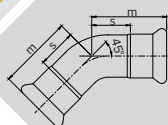
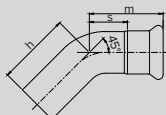

FIG.6



MAT: AISI 316L



### 90° M-F ELBOW

Dimensions	m	h	s	N° pieces/Bag	Art. N°
15	48	67	28	20	GASF04156
18	52	65	32	20	GASF04186
22	61	74	40	20	GASF04226
28	71,5	82	49	10	GASF04286
35	74	85	48	10	GASF04356
42	86	96,5	56	4	GASF04426
54	105	122	71,5	2	GASF04546
76,1	177	195	123,5	1	GASF04766
88,9	181	202	123	1	GASF04886
108	214	240	140	1	GASF041086
139,7	314	322	216	1	GASF0413926
168,3	386	404	268	1	GASF0416826

### 45° F-F ELBOW

Dimensions	m	s	N° pieces/Bag	Art. N°
15	34,5	14,5	20	GASF05156
18	36	16	20	GASF05186
22	41	20	20	GASF05226
28	46	24	10	GASF05286
35	54,5	28,5	10	GASF05356
42	67,5	37,5	4	GASF05426
54	66,5	33	2	GASF05546
76,1	111	57,5	1	GASF05766
88,9	114	56	1	GASF05886
108	138	64	1	GASF051086
139,7	203	105	1	GASF0513926
168,3	252	134	1	GASF0516826

### 45° M-F ELBOW

Dimensions	m	h	s	N° pieces/Bag	Art. N°
15	34,5	47	14,5	20	GASF06156
18	36	48,5	16	20	GASF06186
22	40	52	20	20	GASF06226
28	46	58	24	10	GASF06286
35	54,5	69	28,5	10	GASF06356
42	67,5	77,5	37,5	4	GASF06426
54	66,5	84	33	2	GASF06546
76,1	111	128	57,5	1	GASF06766
88,9	114	135	56	1	GASF06886
108	138	169	64	1	GASF061086
139,7	203	210	105	1	GASF0613926
168,3	252	253	134	1	GASF0616826

## FEMALE ANGLE ADAPTOR

Dimensions	m <sub>1</sub>	m <sub>2</sub>	s <sub>1</sub>	s <sub>2</sub>	N° pieces/Bag	Art. N°
15-Rp 1/2"	57	37	37	24	20	GASF07151/26
18-Rp 1/2"	57	39	37	26	20	GASF07181/26
18-Rp 3/4"	59	46	39	31	10	GASF07183/46
22-Rp 3/4"	59	46	39	31	10	GASF07223/46
28-Rp 1"	67	54	44	37	10	GASF072816
35-Rp 1 1/4"	75	63	49	44	10	GASF073511/46

FIG.7

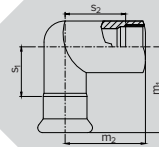
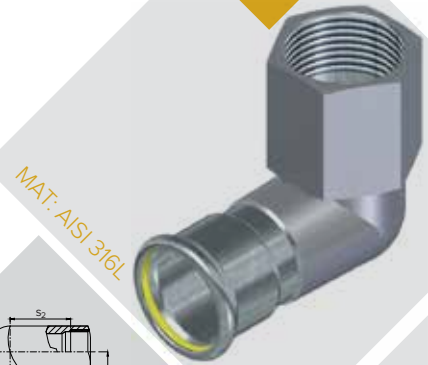

## MALE ANGLE ADAPTOR

Dimensions	m	h	s	N° pieces/Bag	Art. N°
15-R 1/2"	57	37	37	20	GASF08151/26
18-R 1/2"	57	39	37	20	GASF08181/26
18-R 3/4"	59	46	39	10	GASF08183/46
22-R 3/4"	59	46	39	10	GASF08223/46
28-R 1"	67	54	44	10	GASF082816
35-R 1 1/4"	75	63	49	10	GASF083511/46
42-R 1 1/2"	84	67	54	2	GASF084211/26
54-R 2"	93	78	60	2	GASF085426

FIG.8

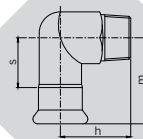

## F ELBOW WITH WALLNUT

Dimensions	m	h	l <sub>1</sub>	l	Ød	e.c.	s	s <sub>1</sub>	(°)	Art. N°
NW-15-Rp 1/2"	14	44	30	50	5	34	28	17	20	GASF09151/26
NW-18-Rp 1/2"	14	44	30	50	5	34	30	17	20	GASF09181/26
NW-22-Rp 3/4"	18	51	34	54	6	40	33	20	20	GASF09223/46

(\*) N° pieces/Bag

FIG.9

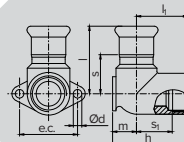
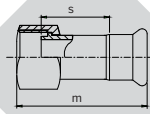
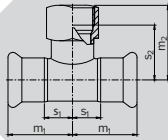

FIG.11



MAT: AISI 316L

FIG.12



MAT: AISI 316L

FIG.14



MAT: AISI 316L

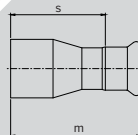

### VALVE CONECT. WITH SWIVEL IN STAINLESS

Dimensions	m	s	N° pieces/Bag	Art. N°
15-Rp 1/2"	63,5	37,5	10	GASF11151/26
18-Rp 1/2"	62	37	10	GASF11181/26
18-Rp 3/4"	61	38	10	GASF11183/46
22-Rp 3/4"	62	39,5	10	GASF11223/46
28-Rp 1"	69,5	43,5	10	GASF112816
35-Rp 1 1/4"	76	42	4	GASF113511/46
42-Rp 1 1/2"	82,5	46	4	GASF114211/26
54-Rp 2"	88	50	4	GASF115426
54-Rp 2 1/2"	105	52,5	1	GASF115421/26
76,1-Rp 2 1/2"	185,5	113	1	GASF117621/26

### F TEE THREADED ADAPTOR

Dimensions	m <sub>1</sub>	m <sub>2</sub>	s <sub>1</sub>	s <sub>2</sub>	(°)	Art. N°
15-Rp 1/2"-15	32	36	12	23	20	GASF12151/26
18-Rp 1/2"-18	34	37	14	24	20	GASF12181/26
18-Rp 3/4"-18	34	41	14	26	20	GASF12183/46
22-Rp 1/2"-22	35,5	39	16	26	20	GASF12221/26
22-Rp 3/4"-22	35,5	44	16	29	20	GASF12223/46
28-Rp 1/2"-28	41	42	19	29	10	GASF12281/26
28-Rp 3/4"-28	41	46	19	31	10	GASF12283/46
28-Rp 1"-28	41	47	19	30	10	GASF122816
35-Rp 1/2"-35	50	45	24	32	10	GASF12351/26
35-Rp 3/4"-35	50	50	24	35	10	GASF12353/46
35-Rp 1"-35	50	51	24	34	10	GASF123516
35-Rp 1 1/4"-35	50	55	24	36	10	GASF123511/46
42-Rp 1/2"-42	57	48	27	35	4	GASF12421/26
42-Rp 3/4"-42	57	52	27	37	4	GASF12423/46
42-Rp 1"-42	57	53	27	34	4	GASF124216
42-Rp 1 1/2"-42	57	61	27	42	4	GASF124211/26
54-Rp 1/2"-54	68	55	34	41	2	GASF12541/26
54-Rp 3/4"-54	68	58	34	43	2	GASF12543/46
54-Rp 1"-54	68	59	34	41	2	GASF125416
54-Rp 2"-54	68	76	34	47	2	GASF125426
76,1-Rp 3/4"-76,1	113	71	59	56	1	GASF12763/46
76,1-Rp 2"-76,1	113	91	59	62	1	GASF127626
88,9-Rp 3/4"-88,9	128	78	70	63	1	GASF12883/46
88,9-Rp 2"-88,9	128	97	70	68	1	GASF128826
108-Rp 3/4"-108	150	87	81	72	1	GASF121083/46
108-Rp 2"-108	150	107	81	78	1	GASF1210826
139,7-2"-139,7	197	123	99	94	1	GASF12139226
139,7-3/4-139,7	197	105,5	99	90,5	1	GASF121393/426

(\*) N° pieces/Bag

### MF REDUCER

D	m	s	(°)	Art. N°	D	m	s	(°)	Art. N°
18-15	62	42	20	GASF1418156	76.1-22	122	100.5	1	GASF1476226
22-15	64	44	20	GASF1422156	76.1-28	123	101	1	GASF1476286
22-18	60	40	20	GASF1422186	76.1-35	126	100	1	GASF1476356
28-15	68	48	20	GASF1428156	76.1-42	130	100	1	GASF1476426
28-18	66	46	20	GASF1428186	76.1-54	132	98	1	GASF1476546
28-22	65	45,5	20	GASF1428226	88.9-42	159	129	1	GASF1488426
35-15	77	57	10	GASF1435156	88.9-54	162	128	1	GASF1488546
35-18	77	57	10	GASF1435186	88.9-76.1	185	131	1	GASF1488766
35-22	82,5	61,5	10	GASF1435226	108-54	179	145	1	GASF14108546
35-28	74	52	10	GASF1435286	108-76.1	198	145	1	GASF14108766
42-15	85	65	4	GASF1442156	108-88.9	206	148	1	GASF14108886
42-18	87	67	4	GASF1442186	139.7-76.1	347	293	1	GASF141397626
42-22	88,0	66,5	4	GASF1442226	139.7-88.9	340	282	1	GASF141398826
42-28	82	60	4	GASF1442286	139.7-108	307	236	1	GASF1413910826
42-35	88	62	4	GASF1442356	168.3-76.1	278	210	1	GASF141687626
54-15	92	72	4	GASF1454156	168.3-88.9	379	321	1	GASF141688826
54-18	93	72,0	4	GASF1454186	168.3-108	360	289	1	GASF1416810826
54-22	93,5	72,5	4	GASF1454226	168.3-139.7	422	324	1	GASF1416813926
54-28	93	71	4	GASF1454286					
54-35	101	75	4	GASF1454356					
54-42	101	71	4	GASF1454426					

(\*) N° pieces/Bag



## REDUCING TEE

Dimensions	m <sub>1</sub>	m <sub>2</sub>	s <sub>1</sub>	s <sub>2</sub>	(*)	Art. N°
18-15-18	34	40	14	20	20	GASF151815186
22-15-22	35,5	42	16	22	20	GASF152215226
22-18-22	35,5	42	16	22	20	GASF152218226
28-15-28	41	45	19	25	10	GASF152815286
28-18-28	41	45	19	25	10	GASF152818286
28-22-28	41	45	19	25	10	GASF152822286
35-15-35	50	48	24	28	10	GASF153515356
35-18-35	50	48	24	28	10	GASF153518356
35-22-35	50	48	24	28	10	GASF153522356
35-28-35	50	51	24	28	10	GASF153528356
42-15-42	57	51,5	27	31,5	4	GASF154215426
42-18-42	57	52	27	31	4	GASF154218426
42-22-42	57	51	27	31	4	GASF154222426
42-28-42	57	53	27	31	4	GASF154228426
42-35-42	57	57	27	31	4	GASF154235426
54-15-54	68	56,5	34	37,5	2	GASF155415546
54-18-54	68	56,5	34	37,5	2	GASF155418546
54-22-54	68	57	34	37,5	2	GASF155422546
54-28-54	68	60	34	38	2	GASF155428546
54-35-54	68	63	34	37	2	GASF155435546
54-42-54	68	67	34	37	2	GASF155442546
76,1-22-76,1	113	68	59	48	1	GASF157622766
76,1-28-76,1	113	72	59	49	1	GASF157628766
76,1-35-76,1	113	74	59	48	1	GASF157635766
76,1-42-76,1	113	76	59	46	1	GASF157642766
76,1-54-76,1	113	83	59	46,7	1	GASF157654766
88,9-22-88,9	128	75	72	55	1	GASF158822886
88,9-28-88,9	128	79	72	56	1	GASF158828886
88,9-35-88,9	128	81	72	55	1	GASF158835886
88,9-42-88,9	128	83	72	53	1	GASF158842886
88,9-54-88,9	128	90	72	53,7	1	GASF158854886
88,9-76,1-88,9	128	115	72	63	1	GASF158876886
108-22-108	150	84	81	64	1	GASF15108221086
108-28-108	150	88	81	65	1	GASF15108281086
108-35-108	150	90	81	64	1	GASF15108351086
108-42-108	150	95	81	65	1	GASF15108421086
108-54-108	150	99	81	65	1	GASF15108541086
108-76,1-108	150	126,5	81	73	1	GASF15108761086
108-88,9-108	150	136	81	74	1	GASF15108881086
139,7-76,1-139,7	197	143	99	88	1	GASF151397613926
139,7-88,9-139,7	197	153	99	95	1	GASF151398813926
139,7-108-139,7	197	167	99	96	1	GASF1513910813926
168,3-76,1-168,3	257	157	139	103	1	GASF151687616826
168,3-88,9-168,3	257	167	139	110	1	GASF151688816826
168,3-108-168,3	257	182	139	111	1	GASF1516810816826
168,3-139,7-168,3	257	211	139	113	1	GASF1516813916826

(\*) N° pieces/Bag

FIG.15

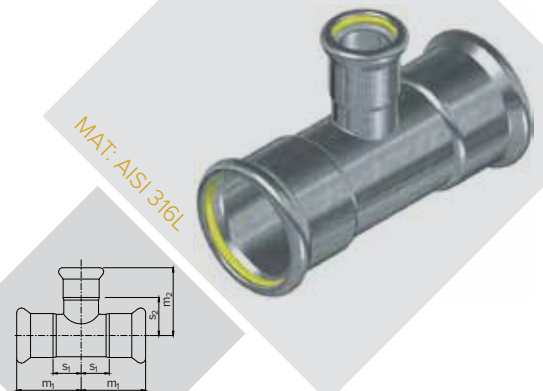
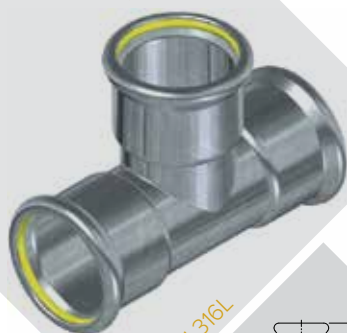
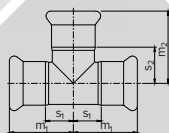

FIG.16



MAT: AISI 316L



### EQUAL TEE

Dimensions	m <sub>1</sub>	m <sub>2</sub>	s <sub>1</sub>	s <sub>2</sub>	(°)	Art. N°
15	32	39	12	19	20	GASF16156
18	34	39	14	19	20	GASF16186
22	35,5	42	16	21	20	GASF16226
28	41	47	19	25	10	GASF16286
35	50	53	24	27	10	GASF16356
42	57	60	27	30	4	GASF16426
54	68	71	34	37	2	GASF16546
76,1	113	110	59	55	1	GASF16766
88,9	128	128	72	69	1	GASF16886
108	150	154	81	85	1	GASF161086
139,7	197	197	99	99	1	GASF1613926
168,3	257	235	139	118	1	GASF1616826

(\*) N° pieces/Bag

FIG.17



MAT: AISI 316L

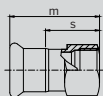

### FEMALE ADAPTOR

Dimensions	m	s	N° pieces/Bag	Art. N°
15-Rp 3/8"	54	34	20	GASF17153/86
15-Rp 1/2"	54	34	20	GASF17151/26
15-Rp 3/4"	58	38	20	GASF17153/46
18-Rp 1/2"	54	34	20	GASF17181/26
18-Rp 3/4"	58	38	20	GASF17183/46
22-Rp 1/2"	52	32,5	20	GASF17221/26
22-Rp 3/4"	58	38	20	GASF17223/46
22-Rp 1"	59	39,5	20	GASF172216
28-Rp 3/4"	60	38	20	GASF17283/46
28-Rp 1"	60,5	38,5	20	GASF172816
28-Rp 1 1/4"	65	43	20	GASF172811/46
35-Rp 1"	64	38	10	GASF173516
35-Rp 1 1/4"	69	43	10	GASF173511/46
35-Rp 1 1/2"	73	47	10	GASF173511/26
42-Rp 1 1/4"	72	42	4	GASF174211/46
42-Rp 1 1/2"	77	47	4	GASF174211/26
54-Rp 1 1/2"	81	47	4	GASF175411/26
54-Rp 2"	90	56	4	GASF175426
76,1-Rp 2 1/2"	129	75,5	1	GASF177621/26
88,9-Rp 3"	118	60,5	1	GASF178836



## MALE ADAPTOR

Dimensions	m	s	N° pieces/Bag	Art. N°
15-R 3/8"	48	28	20	GASF18153/86
15-R 1/2"	53,5	33,5	20	GASF18151/26
15-R 3/4"	57,5	37,5	20	GASF18153/46
18-R 1/2"	53,5	33,5	20	GASF18181/26
18-R 3/4"	58	38	20	GASF18183/46
22-R 1/2"	53	33,5	20	GASF18221/26
22-R 3/4"	57	37,5	20	GASF18223/46
22-R 1"	60,5	41	20	GASF182216
28-R 3/4"	60	38	20	GASF18283/46
28-R 1"	63	41	20	GASF182816
28-R 1 1/4"	67	45	20	GASF182811/46
35-R 1"	67	41	10	GASF183516
35-R 1 1/4"	71	45	10	GASF183511/46
35-R 1 1/2"	74	48	10	GASF183511/26
42-R 1 1/4"	75	45	4	GASF184211/46
42-R 1 1/2"	78	48	4	GASF184211/26
54-R 1 1/2"	82	48	4	GASF185411/26
54-R 2"	84	50	4	GASF185426
76,1-R 2 1/2"	127,5	74	1	GASF1821/26
88,9-R 3"	142	86	1	GASF188836
108-R 4"	155	73	1	GASF1810846

FIG.18

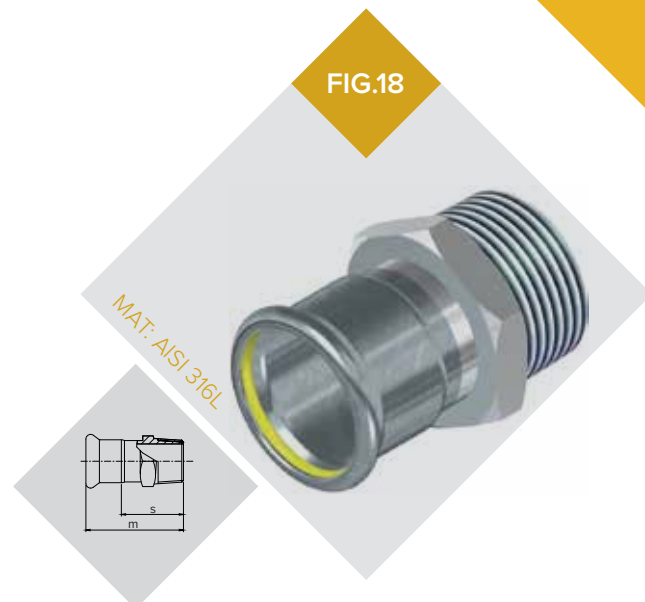

## FLANGES ADAPTOR

Dimensions	D	k	b	d <sub>2</sub>	h	n*	z	(*)	Art. N°
15-DN 15	95	65	14	14	45	4	25	1	GASF19156
18-DN 15	95	65	14	14	47	4	27	1	GASF19186
22-DN 20	105	75	16	14	52	4	31	1	GASF19226
28-DN 25	115	85	16	14	56	4	34	1	GASF19286
35-DN 32	140	100	18	18	66	4	40	1	GASF19356
42-DN 40	150	110	18	18	74	4	44	1	GASF19426
54-DN 50	165	125	18	18	85	4	51	1	GASF19546
76,1-DN 65	185	145	20	18	132	4	78	1	GASF19766
88,9-DN 80	200	160	20	18	146	8	91	1	GASF19886
108-DN 100	220	180	20	18	169	8	100	1	GASF191086

n\* = Número de tal. de Ø d<sub>2</sub>

(\*) N° pieces/Bag

FIG.19

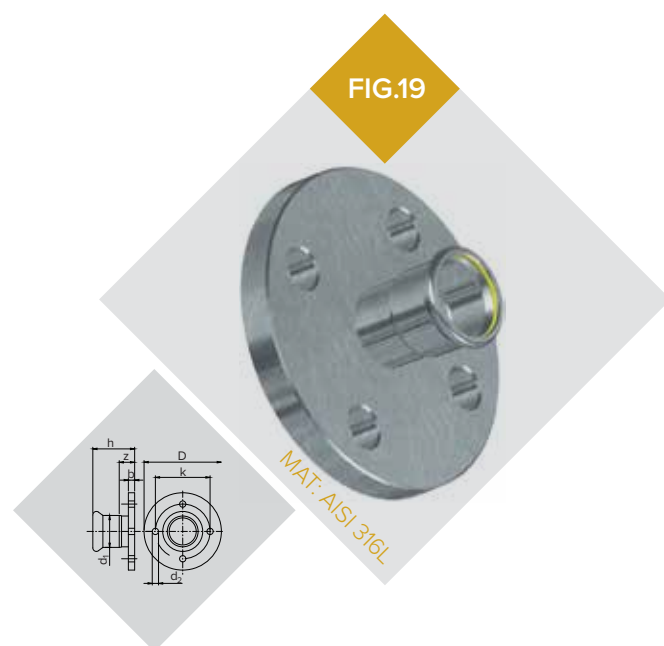
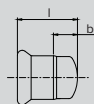

FIG.21



MAT: AISI 316L



### PLUG

Dimensions	l	b	N° pieces/Bag	Art. N°
15	36	16	20	GASF21156
18	36	16	10	GASF21186
22	40	20,5	10	GASF21226
28	42	20	10	GASF21286
35	51	25	10	GASF21356
42	54	24	4	GASF21426
54	59	25	4	GASF21546
76,1	90	36	1	GASF21766
88,9	102	45	1	GASF21886
108	125	56	1	GASF211086

FIG.28



MAT: AISI 316L

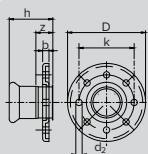

### PRESS FLANGED ADAPTOR

Dimensions	D	k	b	d <sub>2</sub>	h	n*	z	(°)	Art. N°
54-DN 50	165	125	19	17,5	78	4	44	1	GASF28546
76,1-DN 65	185	145	20	17,5	112	4	70	1	GASF28766
88,9-DN 80	200	160	20	17,5	128	8	70	1	GASF28886
108-DN 100	220	180	20	17,5	161	8	86	1	GASF281086
139,7-DN 125	250	210	22	18	138	8	41	1	GASF2813926
168,3-DN 150	285	240	24	22	171	8	54	1	GASF2816826

(\*) N° pieces/Bag

FIG.41



MAT: AISI 316L

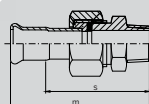

### MALE UNION CONNECTOR GAS

Dimensions	m	s	N° pieces/Bag	Art. N°
15-1/2"	72	52	20	GASF41151/26
15-3/4"	74.5	54.5	20	GASF41153/46
18-1/2"	74	54	20	GASF41181/26
18-3/4"	76.5	56.5	20	GASF41183/46
22-1"	83.5	64	20	GASF412216
22-3/4"	79	58	20	GASF41223/46
28-1"	90.5	68.5	20	GASF412816
28-1 1/4"	94	72	20	GASF412811/46
35-1 1/4"	104.5	78.5	10	GASF413511/46
42-1 1/2"	113	83	4	GASF414211/26
54-2"	134	100	2	GASF415426

(\*) N° pieces/Bag

## FEMALE UNION CONNECTOR GAS

Dimensions	m	s	N° pieces/Bag	Art. N°
15-1/2"	67	47	20	GASF42151/26
15-3/4"	69	49	20	GASF42153/46
18-1/2"	69	47	20	GASF42181/26
18-3/4"	71	51	20	GASF42183/46
22-1"	77	57.5	20	GASF422216
22-3/4"	73.5	54	20	GASF42223/46
28-1"	84.5	62.5	20	GASF422816
28-1 1/4"	84.5	62.5	20	GASF422811/46
35-1 1/4"	96	70	10	GASF423511/46
42-1 1/2"	104.5	74.5	4	GASF424211/26
54-2"	126.5	92.5	2	GASF425426

FIG.42

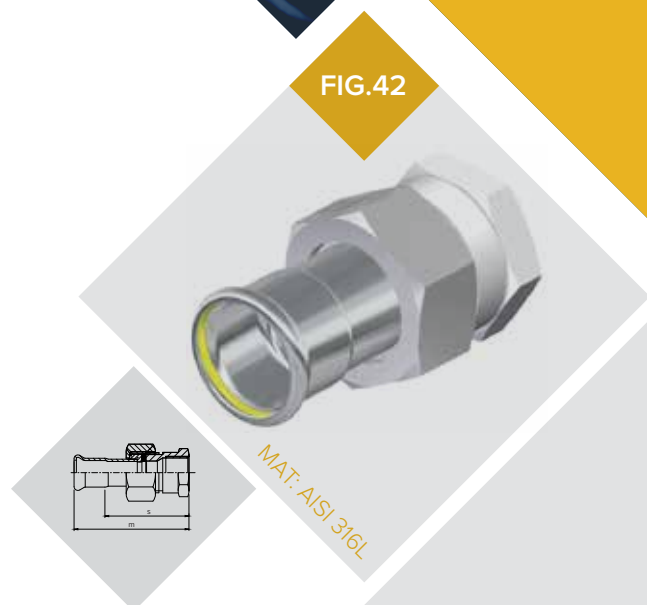

## FEMALE UNION CONNECTOR GAS

Dimensions	m	s	N° pieces/Bag	Art. N°
15-1/2"	63,5	34,5	20	GASF45151/26
15-3/4"	46	19,5	20	GASF45153/46
18-1/2"	65,5	34,5	20	GASF45181/26
18-3/4"	48	21,5	20	GASF45183/46
22-3/4"	65	36,5	20	GASF45223/46
22-1"	50,5	23,5	20	GASF452216
28-1"	73	39,5	20	GASF452816
28-1 1/4"	58	27,5	20	GASF452811/46
35-1 1/4"	76	38	10	GASF453511/46
35-1 1/2"	66,5	32	10	GASF453511/26
42-1 1/2"	82,5	41	4	GASF454211/26
42-2"	75	35,5	4	GASF454226
54-2"	91	47	2	GASF455426

FIG.45



## STRAIGHT UNION WITH PRESSFITTING ON BOTH ENDS

Dimensions	l	b	N° pieces/Bag	Art. N°
15	95	20	20	GASF46156
18	99	20	20	GASF46186
22	104	19.4	20	GASF46226
28	117	22.2	20	GASF46286
35	135.5	26	10	GASF46356
42	152	30	4	GASF46426
54	157	35	2	GASF46546

FIG.46



HNBR



## O-RINGS

Dimensions	N° pieces/Bag
15	10
18	10
22	10
28	10
35	10
42	10
54	10
76,1	4
88,9	4
108	4
139,7	1
168,3	1

For other options please consult the manufacturer



## GENERAL SALES TERMS

All sales made by ISOTUBI, S.L. are according to these general sales terms.

- 1.** All pieces need to be inquired before placing the definitive orders.
- 2.** ISOTUBI, S.L. declines all responsibility for potential damages occurred during transportation.
- 3.** ISOTUBI, S.L. will communicate the minimum amount needed in each order to include transportation cost in the price.
- 4.** The delivery term showed in our order confirmation has only an indicative character.
- 5.** The seller has the right to send a +/- 10% of the quantity ordered by the customer.
- 6.** In case of a non-payment of an invoice at its due-date, ISOTUBI, S.L. will stop all further deliveries.
- 7.** In case of a definitive unpayment ISOTUBI, S.L. will initiate legal actions.
- 8.** ISOTUBI, S.L. won't accept returns of material after 15 days from delivery. In case of a return, it is compulsory to send all documents and information concerning delivery and a report of the defects. ISOTUBI, S.L. won't accept any return of material in case of a bad use of the product by the customer. We warranty our system exclusively when both tubes and fittings have been delivered by ISOTUBI, S.L.
- 9.** ISOTUBI, S.L. won't accept any complaint caused by a negligence in the use of the pressing machines.





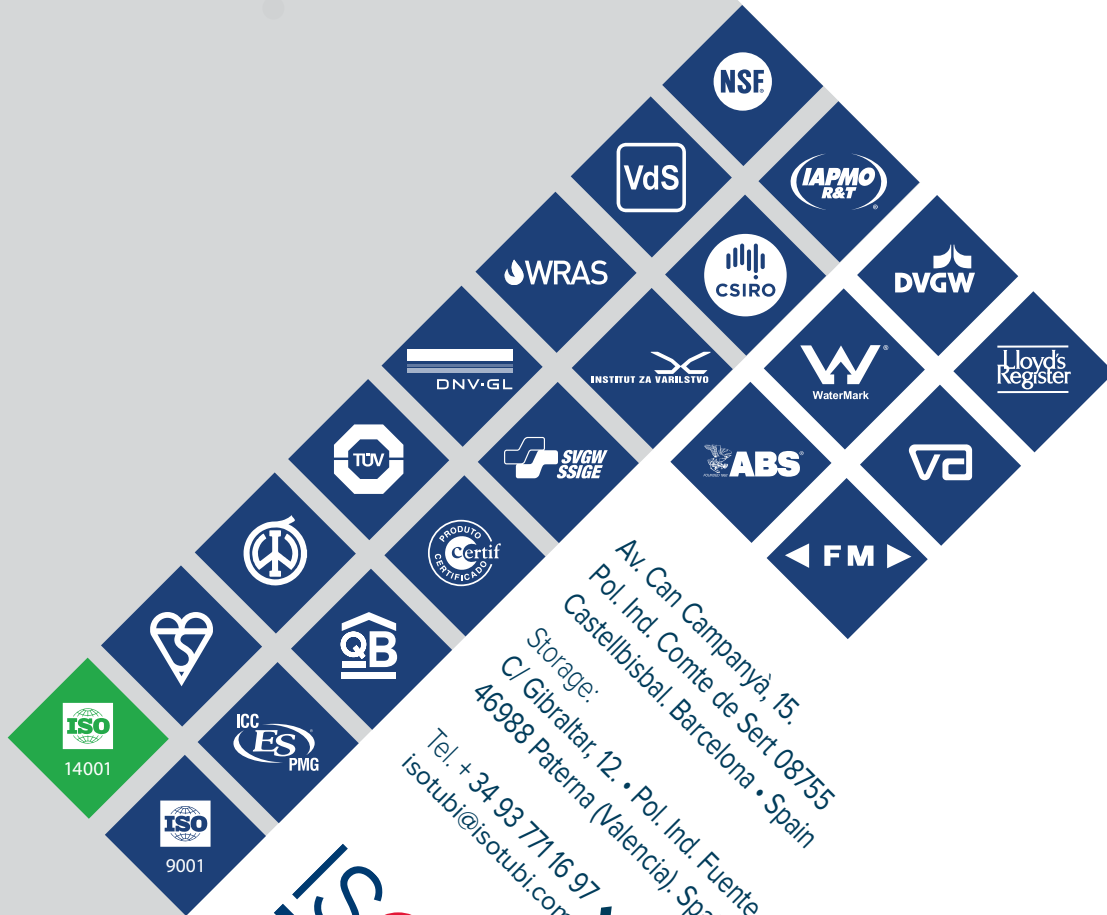

**ISO  
TUBI**

Av. Can Companyà, 15.  
Pol. Ind. Comte de Sert 08755  
Castellbisbal. Barcelona • Spain  
Storage:  
C/ Gibraltar, 12. • Pol. Ind. Fuente del Jarro  
46988 Paterna (Valencia). Spain  
Tel. + 34 93 771 16 97 • Fax. + 34 93 772 19 43  
isotubi@isotubi.com • www.isotubi.com